



# FSY30X05L(M)(H) FSY30X12L(M)(H)

## Features

Size: 30×30×06mm(1.18×1.18×0.24in)

Frame/Impeller: Reinforced Plastic UL94V-0

Bearings: Ball Bearing&Sleeve Bearing

Life Expectancy:50,000 Hours at 20°C-Ball

30,000 Hours at 20°C-Sleeve

Approvals: UL CUL TUV CE RoHS

Weight: 6g



 E318377 CE TUV AE50078959

• RoHS Compliant

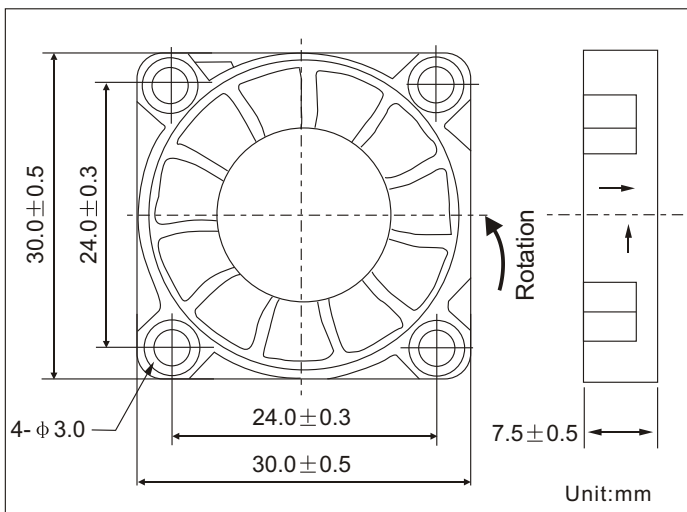

## Air Flow vs Air Pressure

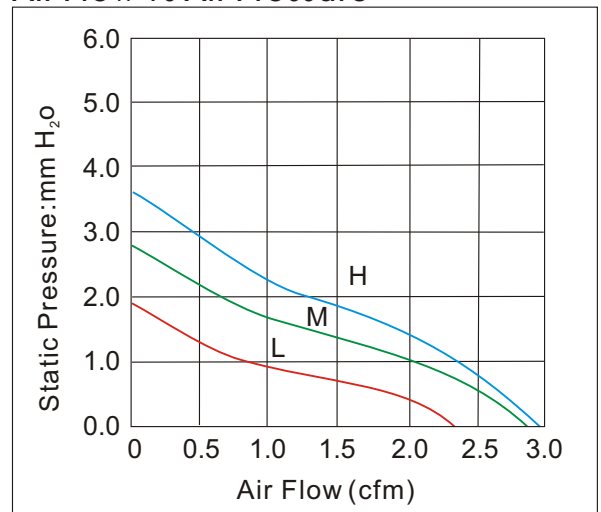

## Performance

Model	Bearing System X			Rated Voltage (V)	Current (A)	Input Power (W)	Nominal Speed (R.P.M)	Air Flow (CFM)	Air Pressure (mm-H <sub>2</sub> O)	Noise (dBA)
	S	B	D							
FSY30X05L	✓	✓	✓	5	0.10	0.50	8000	2.35	1.90	18
FSY30X05M	✓	✓	✓	5	0.12	0.60	9000	2.80	2.85	22
FSY30X05H	✓	✓	✓	5	0.15	0.75	10000	2.95	3.52	25
FSY30X12L	✓	✓	✓	12	0.06	0.72	8000	2.35	1.90	18
FSY30X12M	✓	✓	✓	12	0.08	0.96	9000	2.80	2.85	22
FSY30X12H	✓	✓	✓	12	0.10	1.20	10000	2.95	3.52	25